

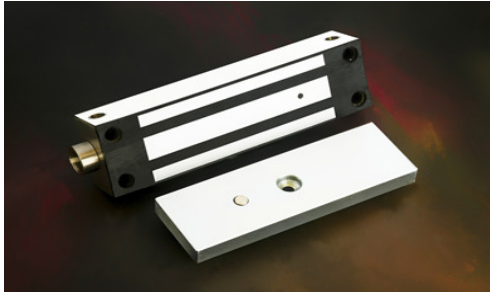

EXT Series

1200lbs Water Proof Electromagnetic Lock

Model EXT545-SLCF (Monitored Version)



Description

1200lbs Water Proof EM locks were designed as such to be unaffected / resisting the ingress of water under specified condition with its fully sealed electronics incased with stainless steel. This EM Lock series is fitted with cable female. Suitable for outdoor application and harsh climate.

Standard Features



Life Safety Applications



No Residual



Low Energy Consumption



Cost Savings

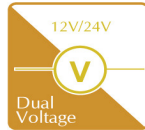

12/24V Selectable



Fully Sealed Electronics

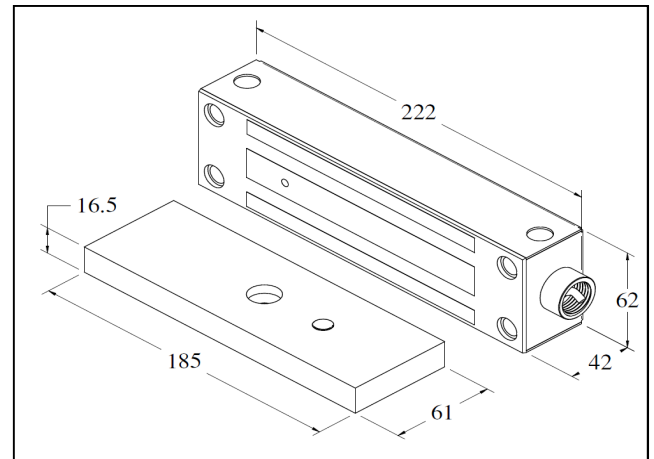

Features & Technical Specification

Models	EXT545-SLCF
Features & Spec.	
Lock Status Monitoring	Reed Switch
Holding Force	Up to 1200lbs
Magnet Size	222 X 62 x 42 mm
Armature Size	185 X 61 X 16.5 mm
Current Drain	420mA±10%/12Vdc / 210mA±10%/24Vdc
Temperature	(-10 to 55) °C (14 to 131) °F
Housing	Stainless Steel Housing
Weight	4.75 Kg

Wiring Diagram

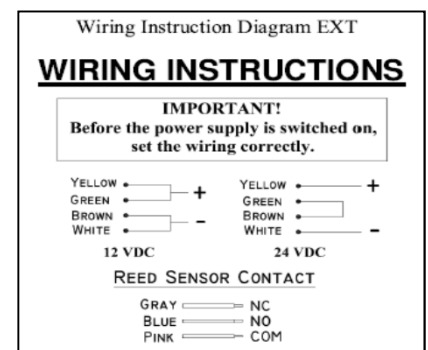

WARRANTY:- Algatec EM Lock are warranted against defects in material and workmanship while used in normal service for a period of 5 years from the date of sale to the original customer.

DISCLAIMER:- Specifications are subject to change without prior notice.

- Attached photo is for reference purpose only, actual product may varies.

